

RHINO-RACK®

Isuzu D-Max (incl. X-Terrain) Gen 3 / Mazda BT-50 Gen 3 Backbone RIDB2

Important:

1. Check the Rhino-Rack website to ensure you have the latest issue of these instructions.
2. Please refer to your fitting instruction to ensure that the roof racks are installed in the correct locations.
3. Check the contents of kit before commencing fitment and report any discrepancies.
4. Place these instructions in the vehicle's glove box after installation is complete.
5. These instructions must be followed for warranty to be upheld.

Fit Time: 1 hour

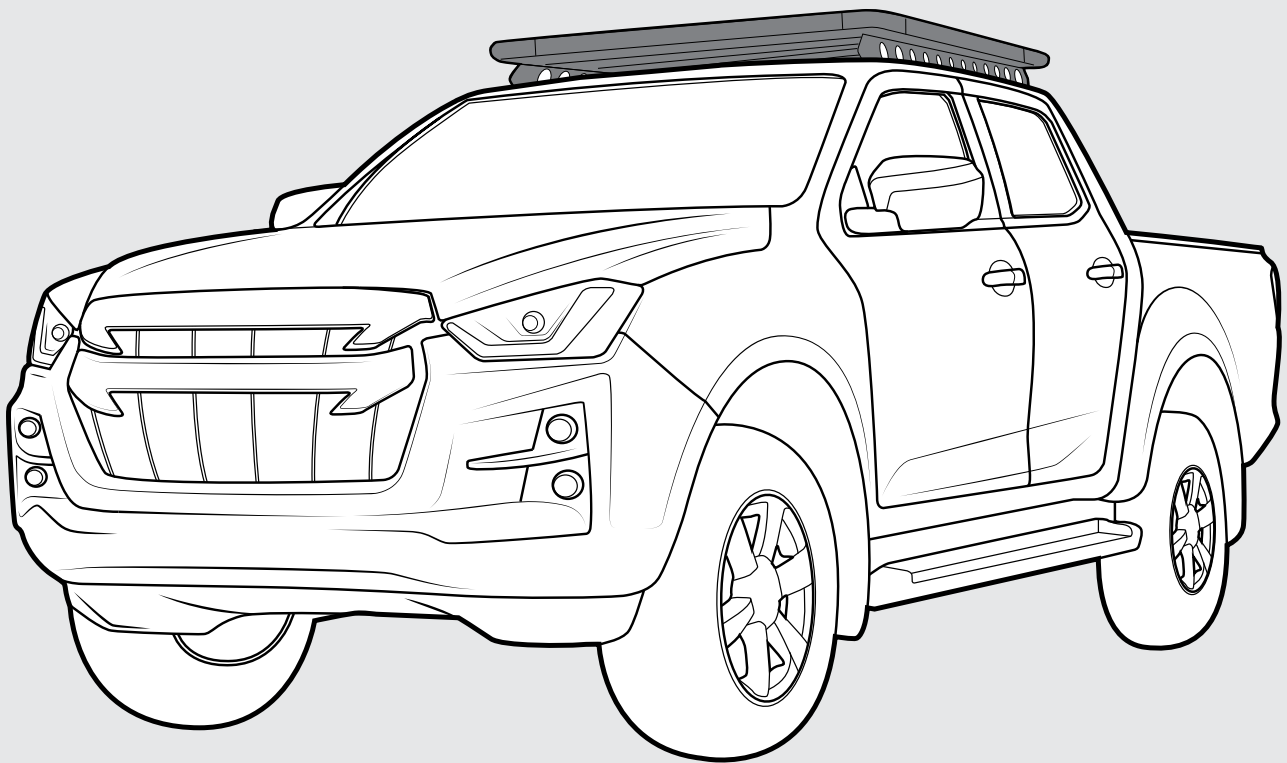

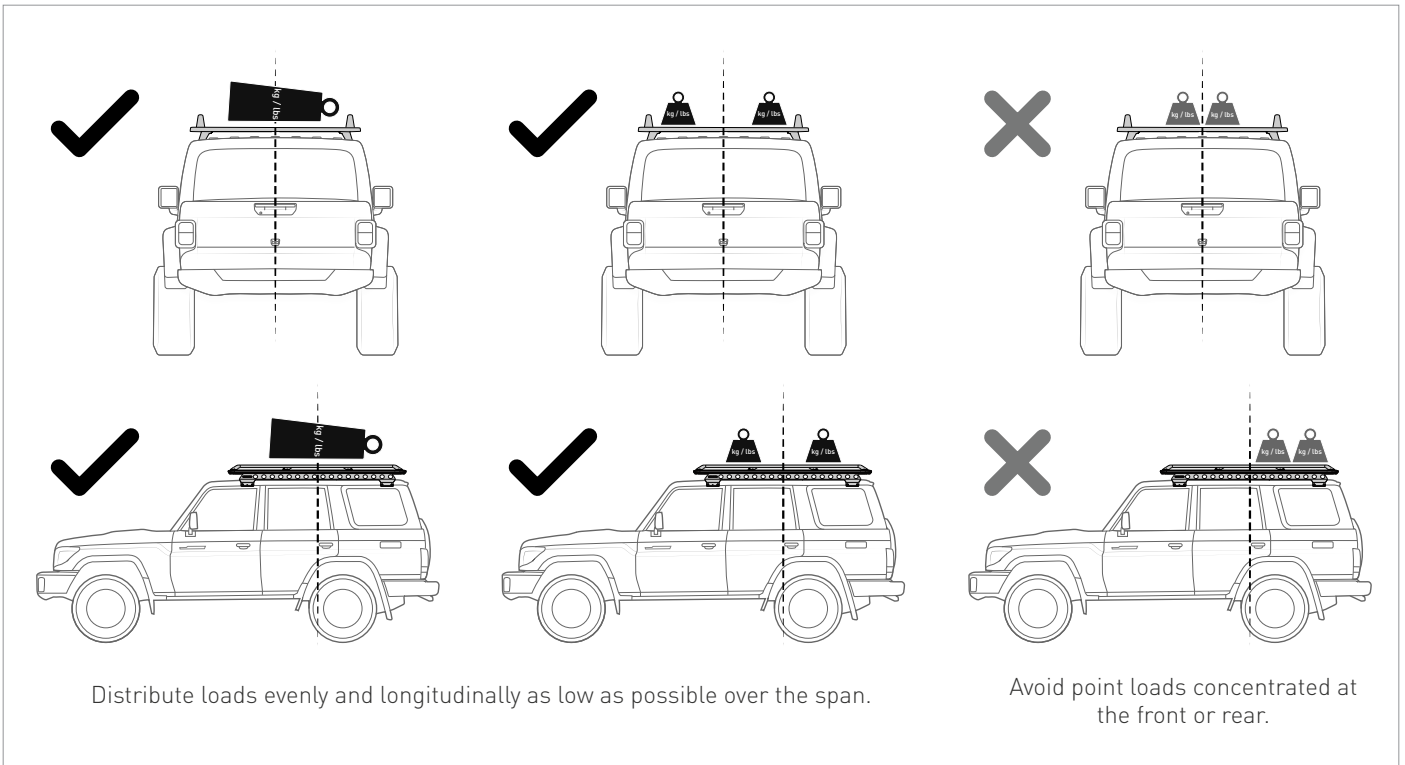

Exercise extreme care when transporting wind-resistant loads. Special consideration must be taken when cornering and braking.

Off-road conditions can be much more rigorous. Extreme care must be taken on any driven path that does not contain a surface protection layer (tar/bitumen).

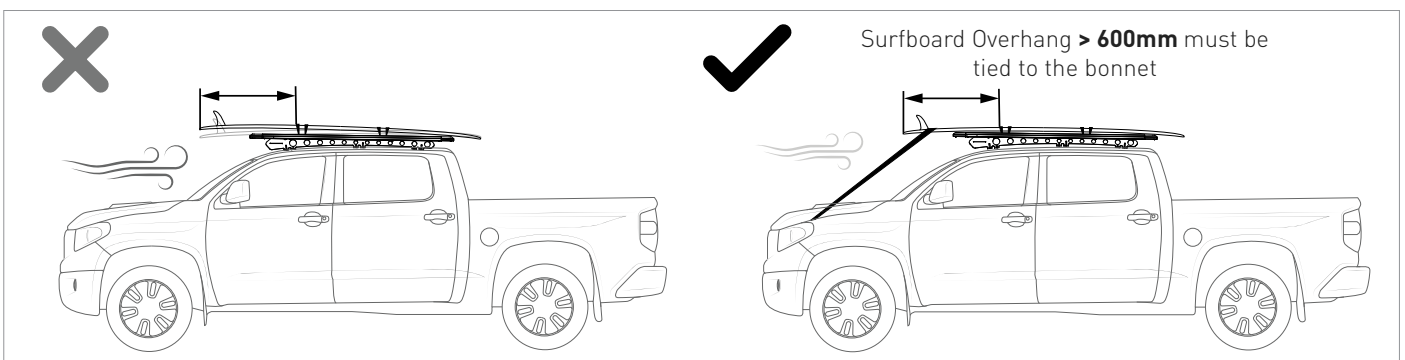
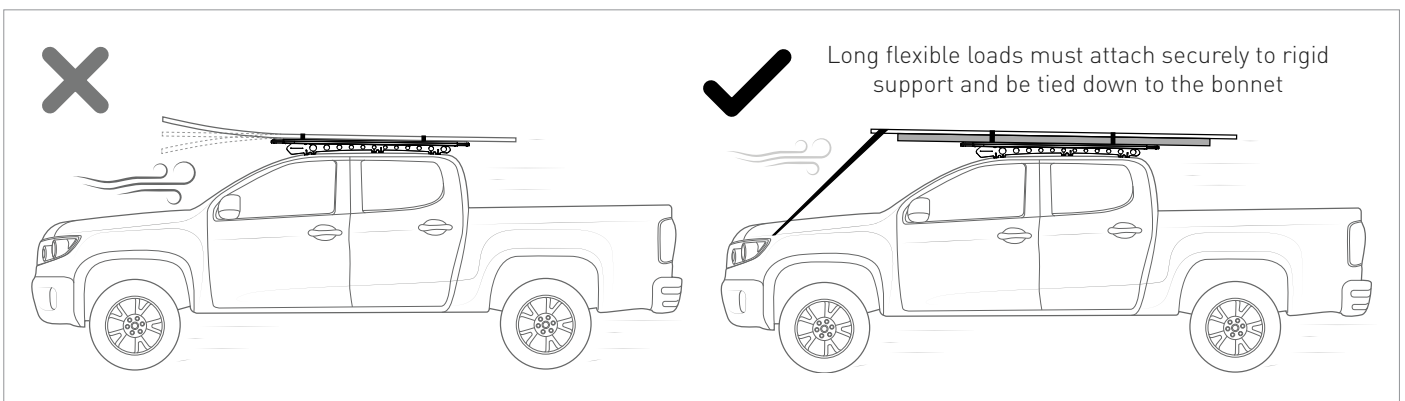
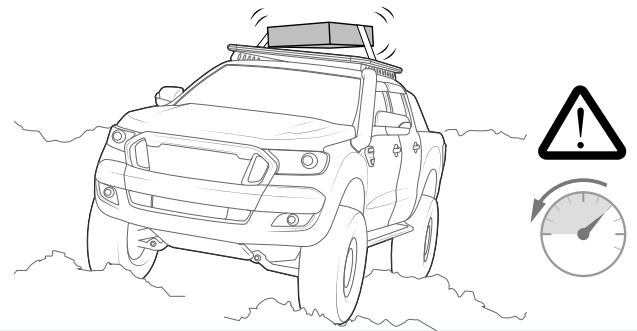
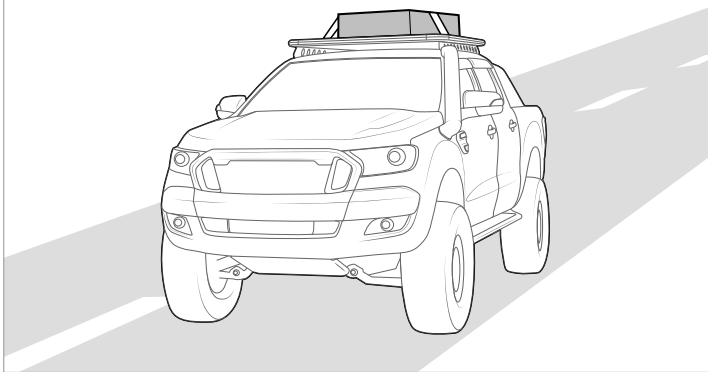

Use only non-stretch fastening ropes or straps to attach cargo to roof racks

Do NOT obstruct windscreen camera sensors

Warranty for roof rack system will be void if the front of the kayak is not secured to the bonnet

Racks must be removed when vehicle is put through an automatic car wash.

Ensure Ladder is well supported on the ground to support tent. Take extreme caution when climbing heights above 1.2m/4ft.

Tub/tray/canopys can move independently from the vehicle cabin. Rigidly fix to either the cabin roof racks **or** the tub/tray/canopy roof racks but not both simultaneously.

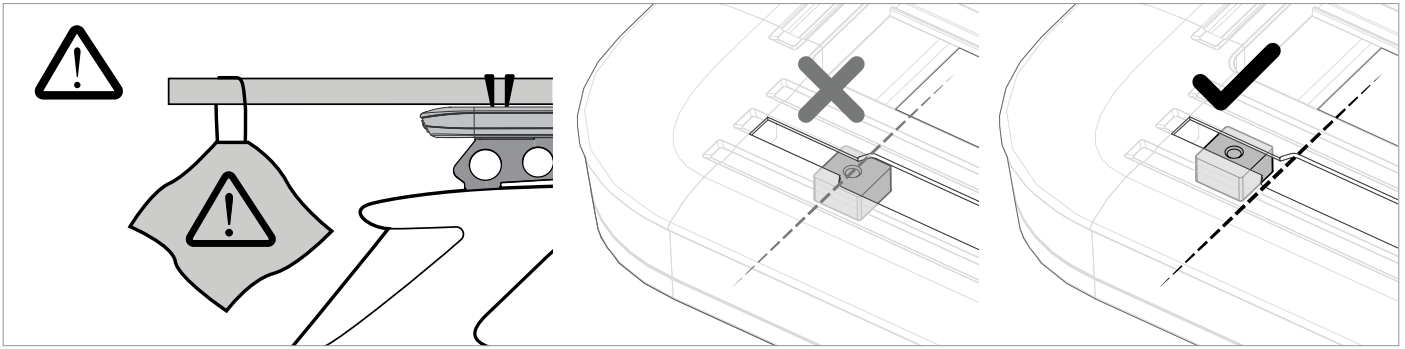

 Ensure sunroof will not collide with roof rack system.





Youtube.com/Rhinorackaustralia

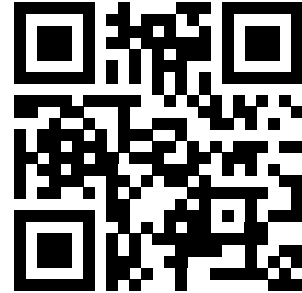

Carrying Capacity

Check the website and the vehicle owners hand book for your vehicle manufacturer's maximum carrying capacity. Load must be evenly distributed over the system.

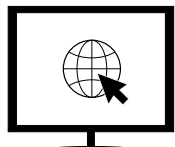

rhinorack.com/
load-rating-calculator



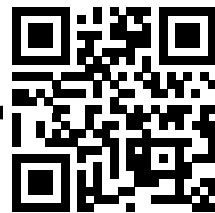

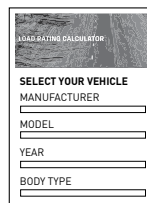



Cargo Load Limit

Total permissible weight allowed on top, and attached to the rack whilst the vehicle is in motion.

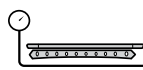

System Weight

Total weight of the rack system. (e.g. Crossbars, Backbone, Platform)



Max System Load Capacity

Please ensure you use the vehicle manufacturer's maximum roof allowance if it is lower than the figure listed in the fitting chart/supplement.



Vehicle Manufacturer's Load Limit

Total permissible weight attached to the rack. This is inclusive of the weight of the rack system.

Warning

- Check part number or kit is correct for use with your vehicle.
- Do not attempt to fit the rack system to your vehicle unless you fully understand these fitting instructions. Please direct any questions regarding fitting to the dealer from where the roof racks were purchased.
- Off-road conditions can be much more rigorous. Extreme care must be taken on any driven path that does not contain a surface protection layer (tar/bitumen).
- Roof racks must be removed when vehicle is put through an automatic car wash.
- With utility vehicles, the cabin and the canopy move independently. Roof racks and vehicle can be damaged if the item transported is rigidly fixed at points on both the cabin and canopy. Instead, rigidly fix to either the cabin roof racks or the canopy roof racks.
- Always ensure you fasten your load securely.
- Use only non-stretch fastening ropes or straps to attach cargo to your load.

In service maintenance checks

- All bolt connections should be checked after driving a short distance when you first install your roof racks.
- All bolted connections should be checked again at regular intervals (weekly is recommended, depending on road conditions, usage, loads and distances travelled).
- All bolted connections should be checked each time they are re-fitted.
- Off-road conditions are more rigorous. Check all bolted connections and your load more regularly.
- Ensure that your vehicle manufacturer's GVM, and gross axle weights are not exceeded (refer to vehicle owner's manual).

Torque Settings:

Unless stated otherwise in these instructions, all fasteners should be set to the following torque settings:

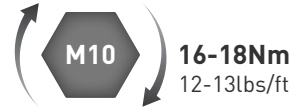
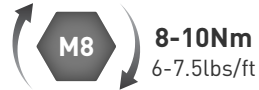







Note for Dealers and Fitters

It is your responsibility to ensure these fitting instructions are given to the end user or client. These instructions remain the property of Rhino-Rack Australia Pty. Ltd. and may not be used or changed for any other purpose than intended.

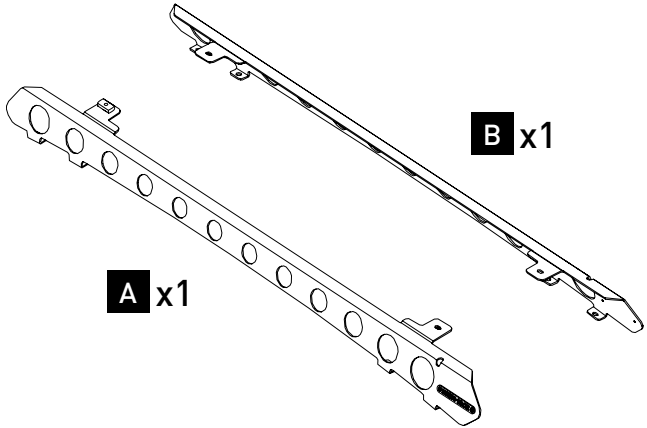
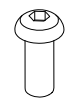
Join the Herd!

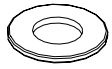
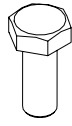
We love creating our products for you and hope you love using them too. For complete peace of mind, register your product at www.rhinorack.com/warranty. This way, we can quickly help you with any future warranty claims. And remember – never to forget to **Make Space For Adventure!**

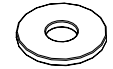
Parts List

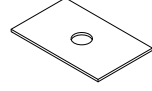
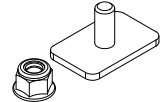
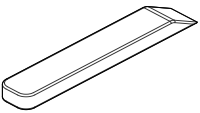
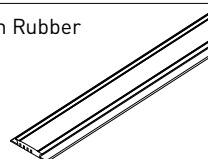
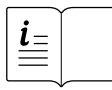
		<p>M8 x 20mm Button HD Cap Screw</p>  <p>C x8</p>	
		<p>M8 Spring Washer S/S</p>  <p>D x8</p>	
<p>M8 x 17mm Flat Washer S/S</p>  <p>E x8</p>	<p>M8 X 20 Hex Set Screw S/S Black</p>  <p>F x4</p>	<p>M8 Spring Washer S/S Black</p>  <p>G x4</p>	<p>M8 x 24 x 2 Flat Washer S/S Black</p>  <p>H x4</p>
<p>M8 Channel Nut Black</p>  <p>I x4</p>	<p>5mm Ball End Allen Key</p>  <p>J x1</p>	<p>Butyl Patch</p>  <p>K x8</p>	<p>Pioneer NG to Backbone Kit</p>  <p>L x4</p>
<p>Nylon Scraper</p>  <p>M x1</p>	<p>1.5M Ditch Rubber</p>  <p>N x2</p>	<p>Instruction</p>  <p>O x1</p>	

Tools Required:

- T1 - Masking Tape
- T2 - Tape Measure
- T3 - Pencil/Marker
- T4 - Chisel
- T5 - Mallet
- T6 - Flat head Screwdriver
- T7 - Knife
- T8 - Cold Galvanising paint
- T9 - Small Paint Brush
- T10 - 13mm Socket Wrench
- T11 - Scissors
- T12 - 12mm Socket Wrench
- T13 - Cleaning rag

NOTES:

For BARE ROOF VARIANT skip Steps **16** - **26**

For ROOF RAIL (D-Max X-Terrain) VARIANT complete Step **1** only then move to Step **16**

1 Repeat to opposite side of vehicle

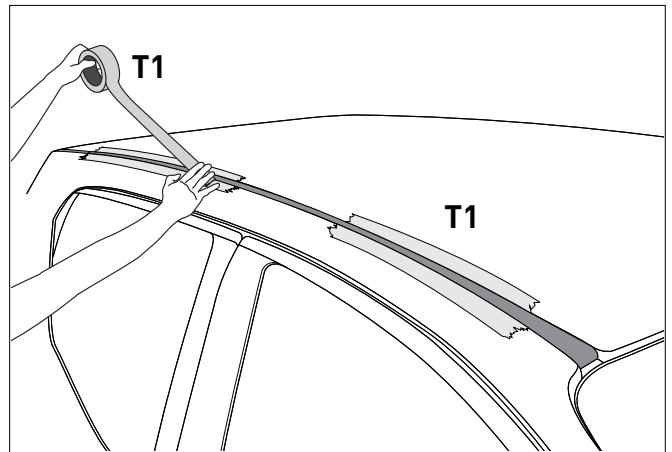
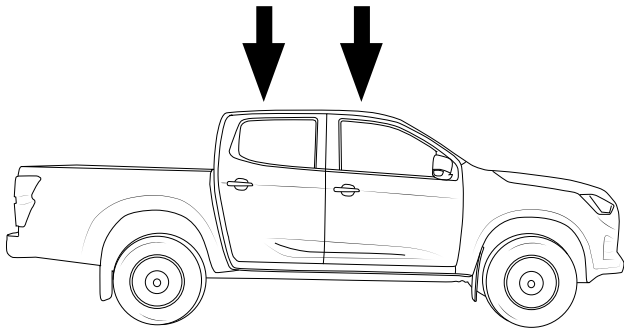

Note: For D-Max X-Terrain only, position tape next to the roof rail end caps, then move to Step **16**

2

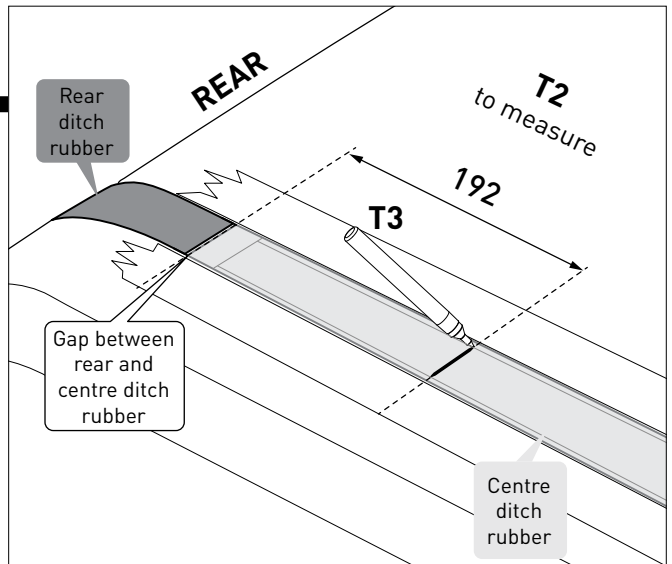
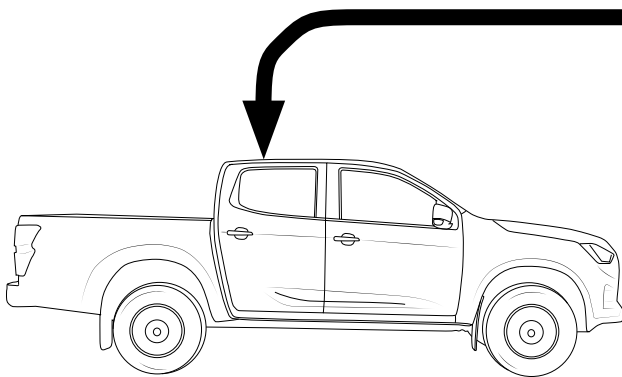

3

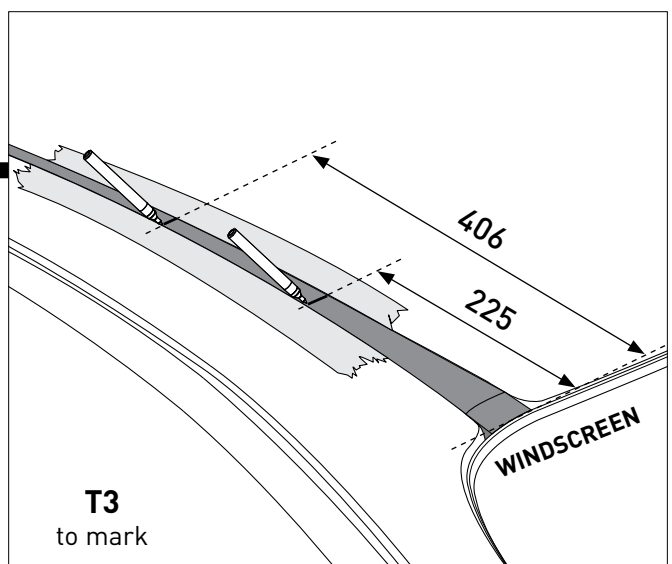
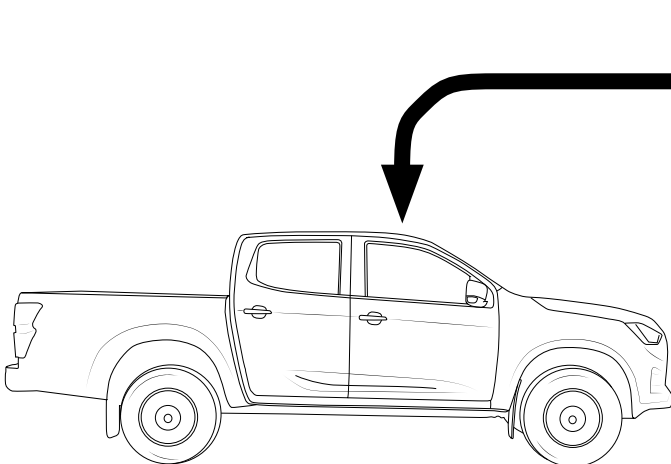

4 Firmly indent the two measured marks on the entire width of the ditch rubber steel reinforcement strip at the front of the vehicle.

T5
T4

Steel reinforcement strip

FRONT

T4

Careful not to hit the top of the vehicle roof

5 Break through the metal strip between the two measured marks made in step 4

T5
T4

5a

T4

45°

Careful not to hit the top of the vehicle roof

5b

T4

45°

Careful not to hit the top of the vehicle roof

6 If necessary, use a knife to cut through any rubber remaining on either side of the metal strip.

Careful not to cut the top of the vehicle roof

7 Wedge a flat head screwdriver underneath the cut in the ditch rubber and lift to separate

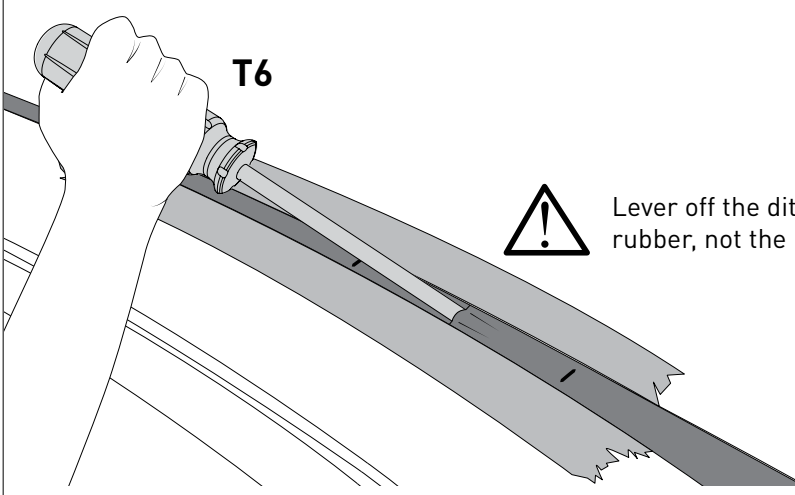

T6

! Lever off the ditch rubber, not the roof

7a

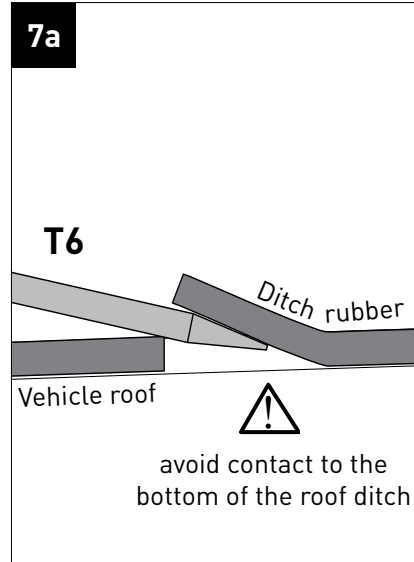

T6

Ditch rubber

Vehicle roof

! avoid contact to the bottom of the roof ditch

8 Work the strip back & forth to snap off then cut through ditch rubber with a knife. Repeat to ditch rubber B.

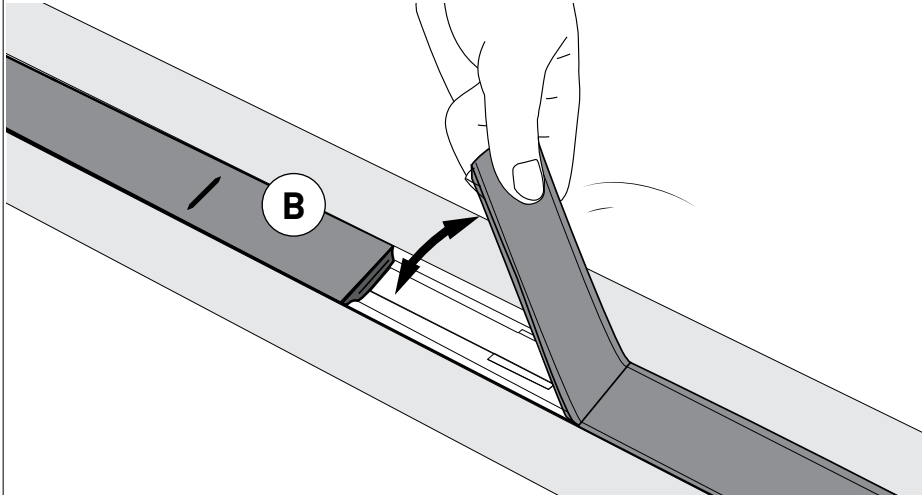

B

8a Trim any excess rubber.

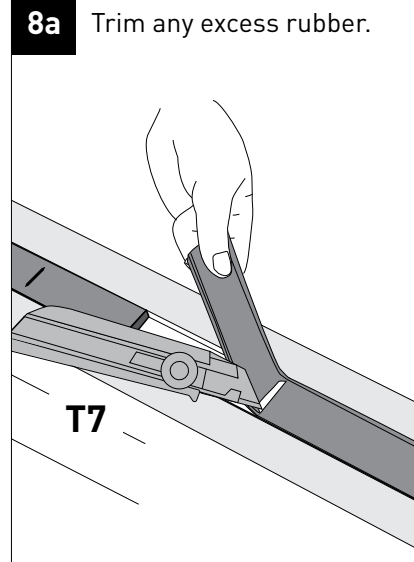

T7

9 Firmly indent the measured mark on the entire width of the ditch rubber steel reinforcement strip at the rear of the vehicle.

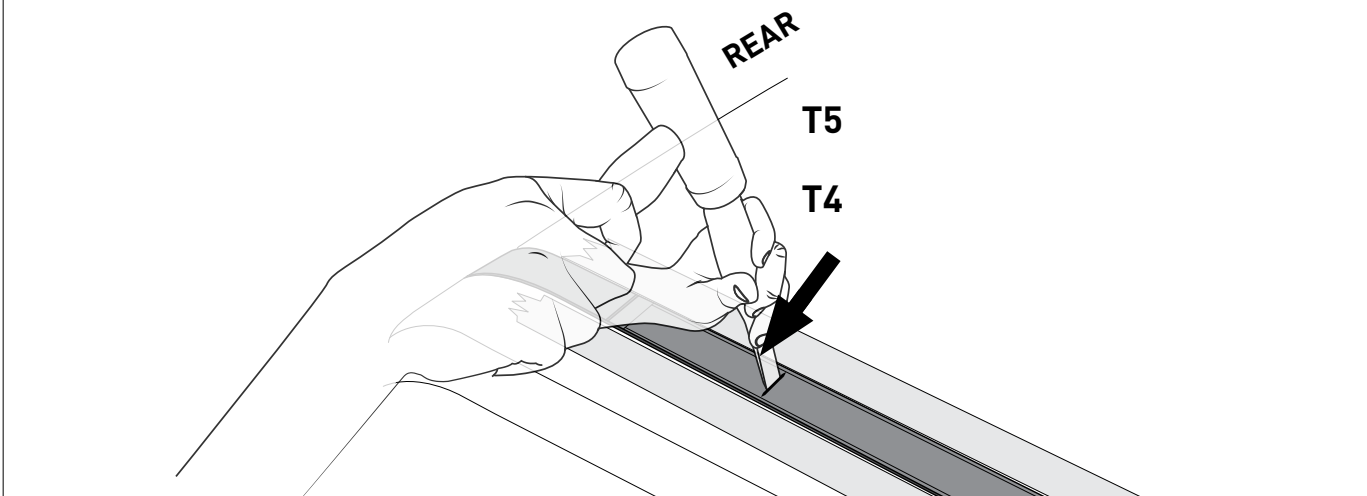

REAR

T5

T4

10

Wedge a flat head screwdriver between the back edge of the ditch rubber and pry upwards to separate.

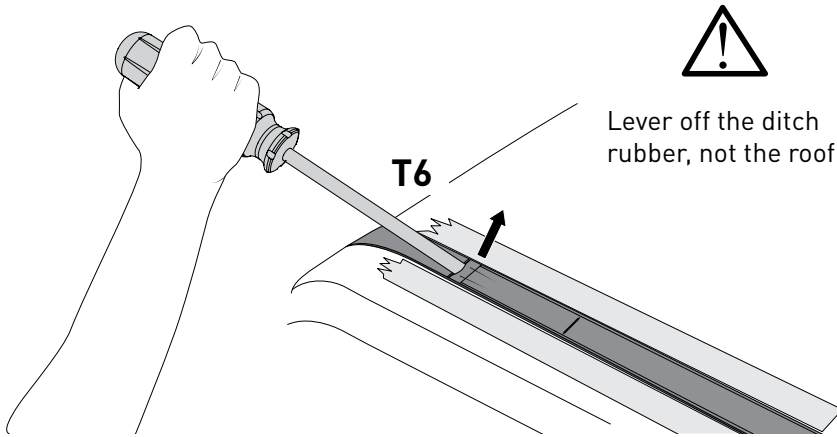

10a

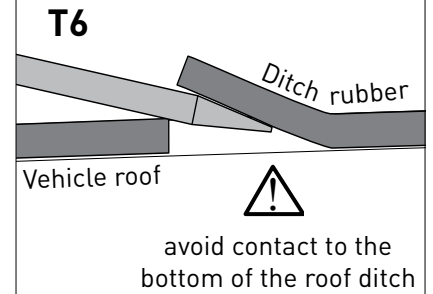

11

Work the strip back & forth to snap off then cut through ditch rubber with a knife.

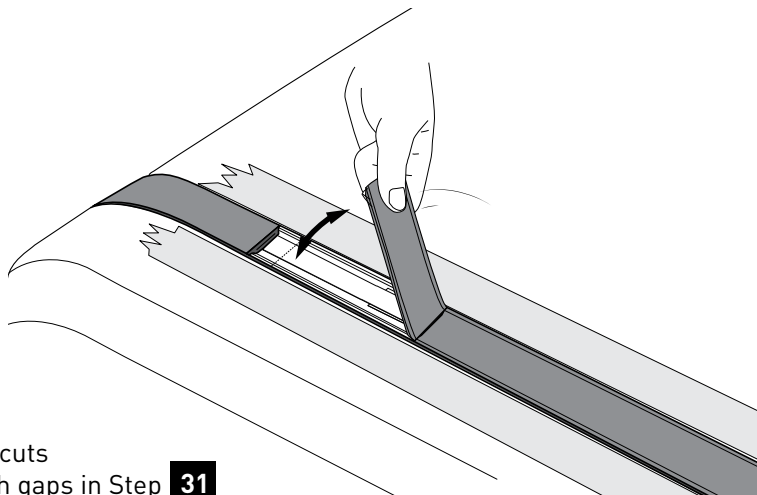

Keep the offcuts to fill in ditch gaps in Step 31

11a

Trim any excess rubber.

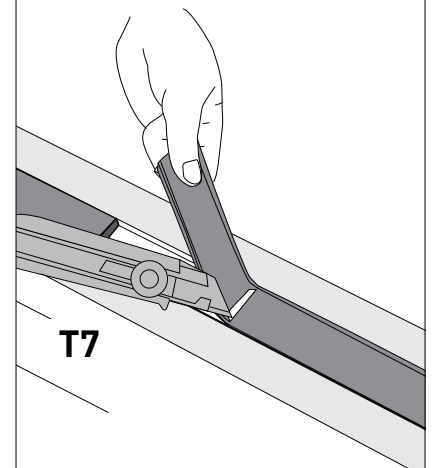

12

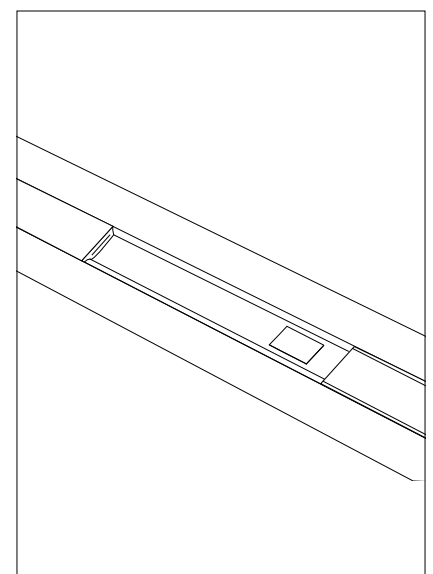
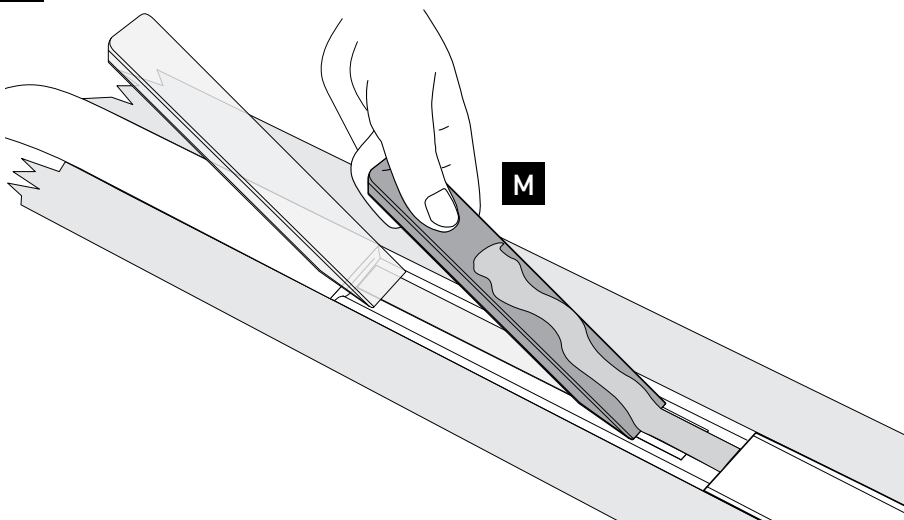

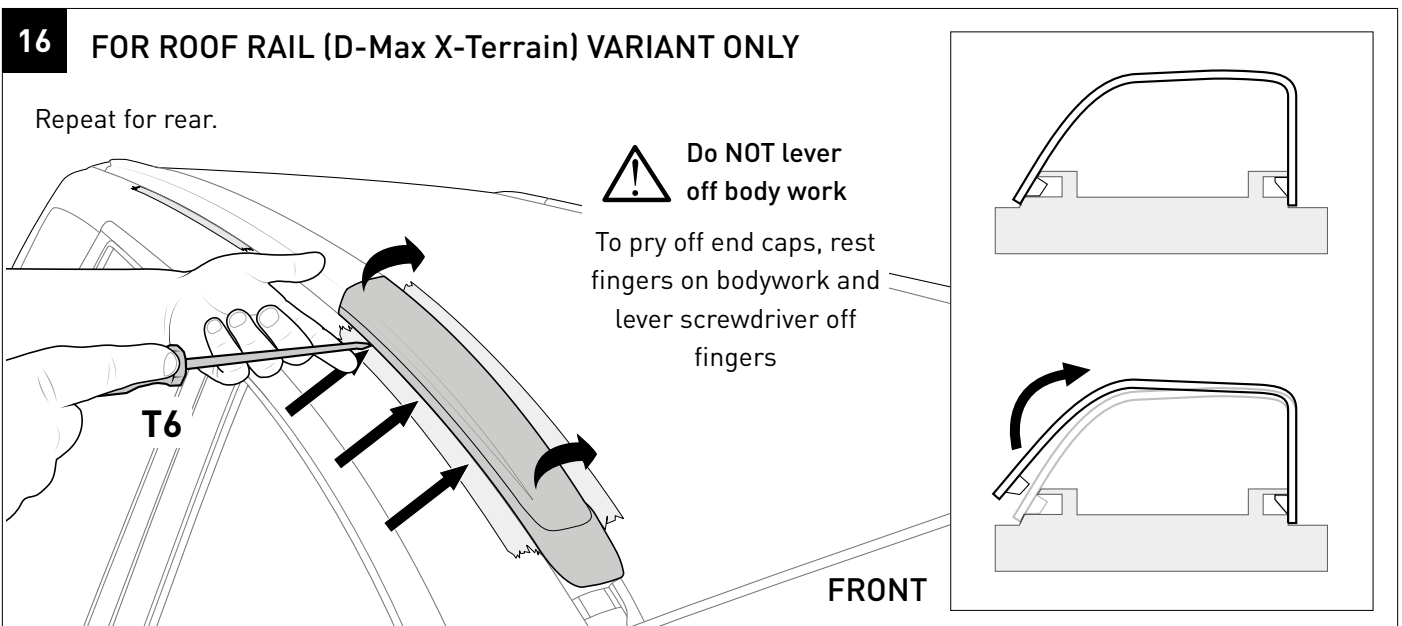
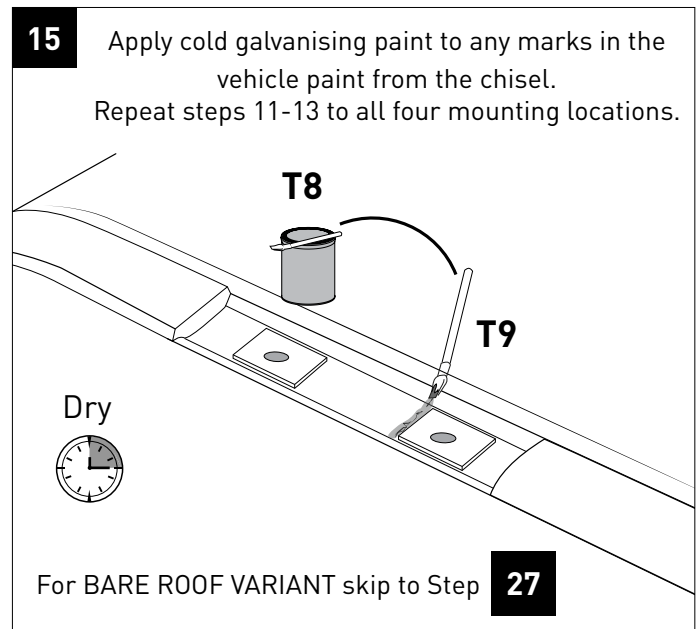
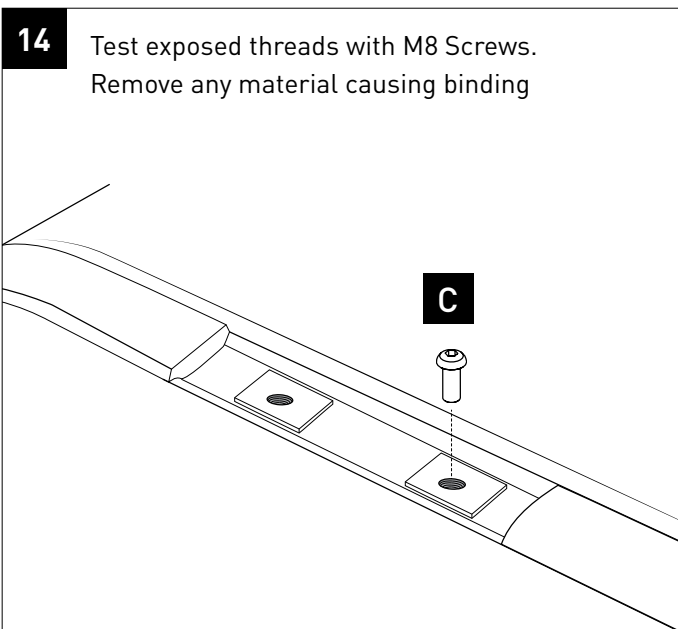
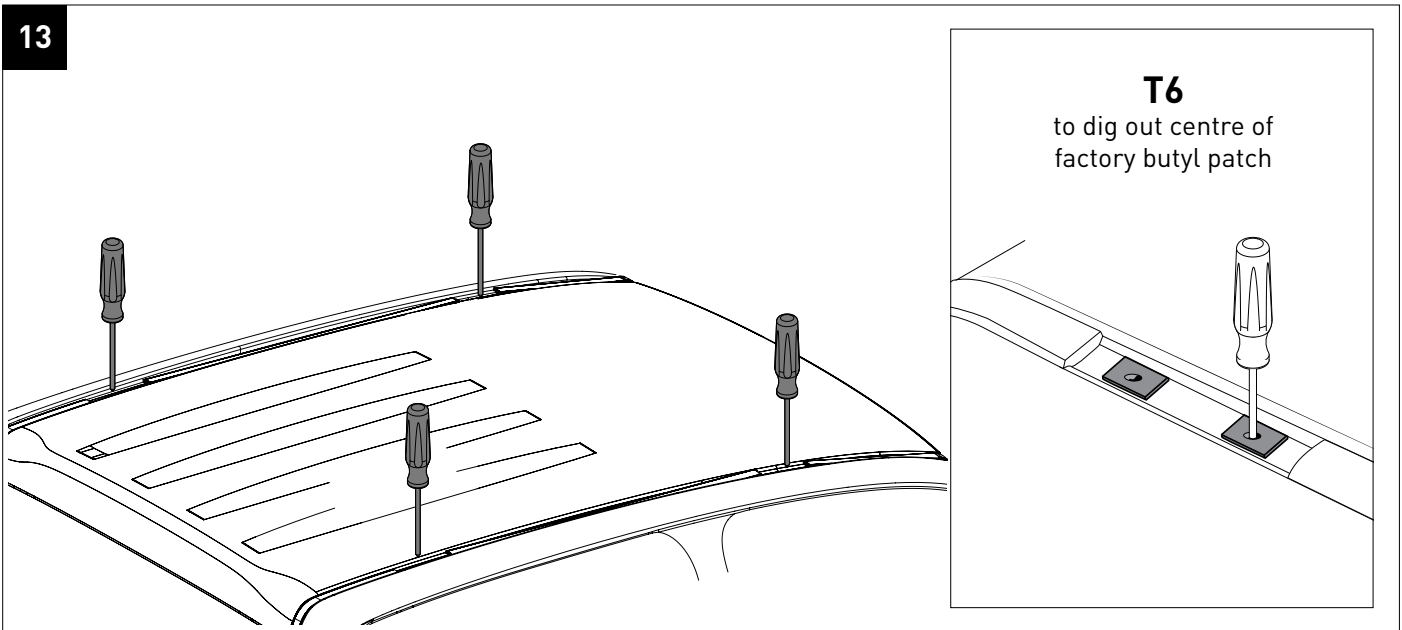

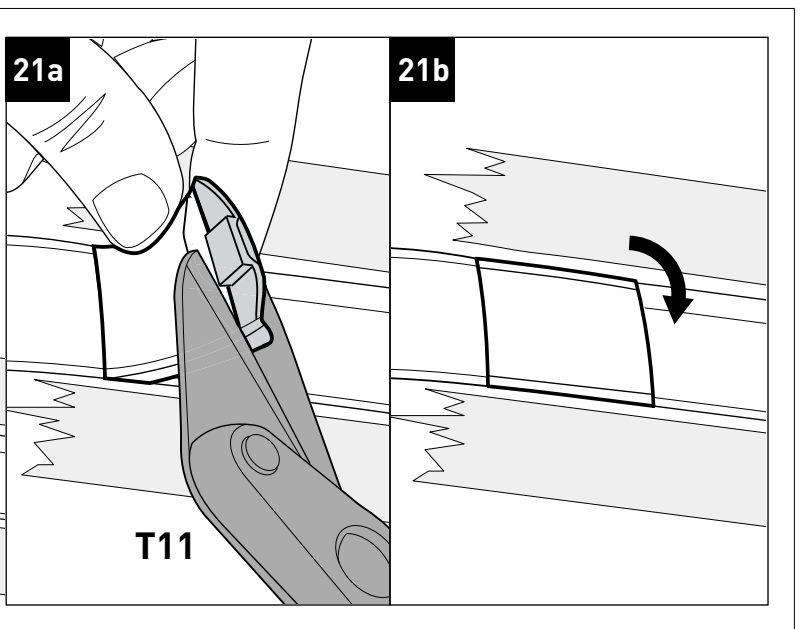
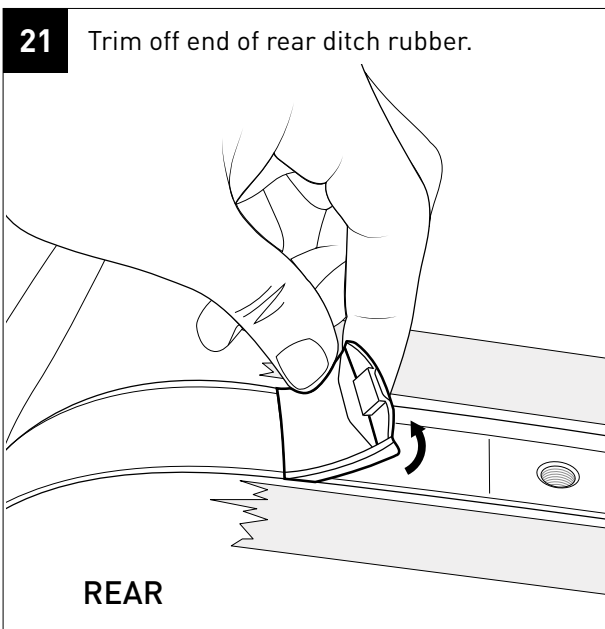
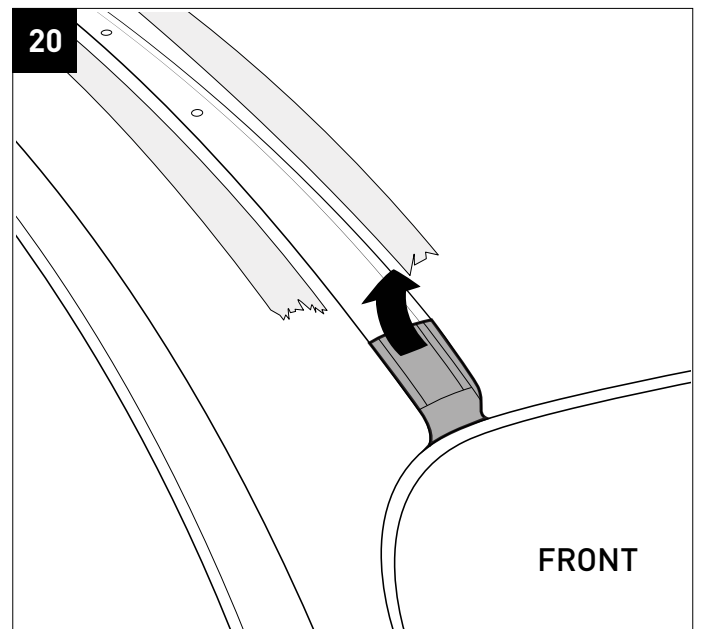
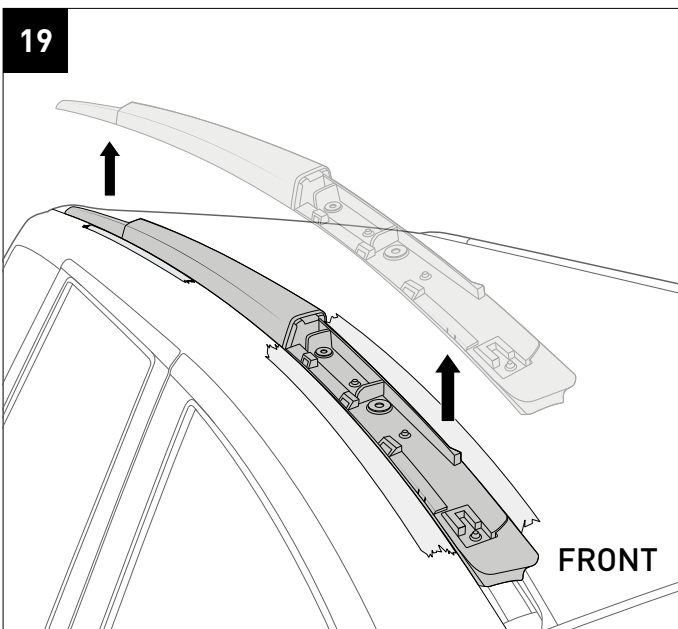
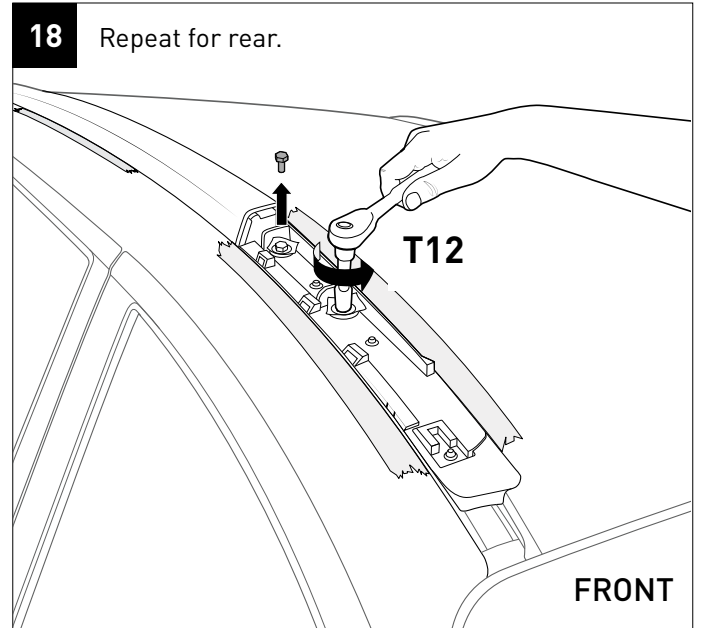
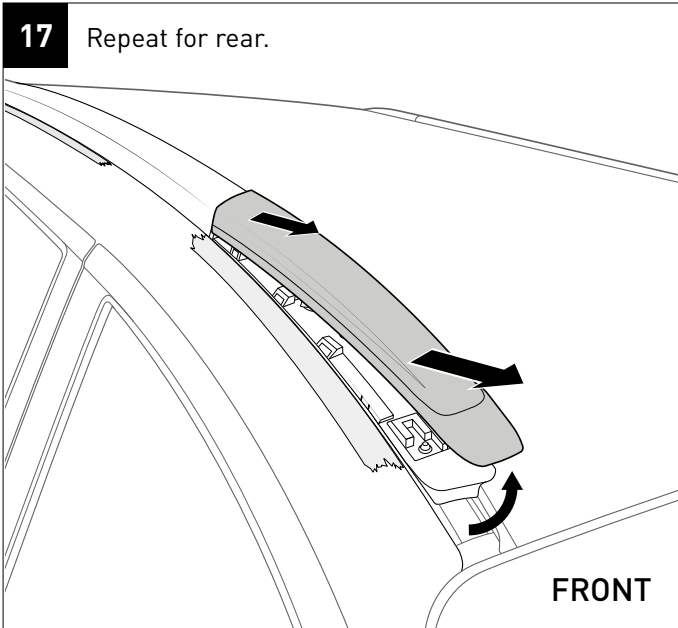

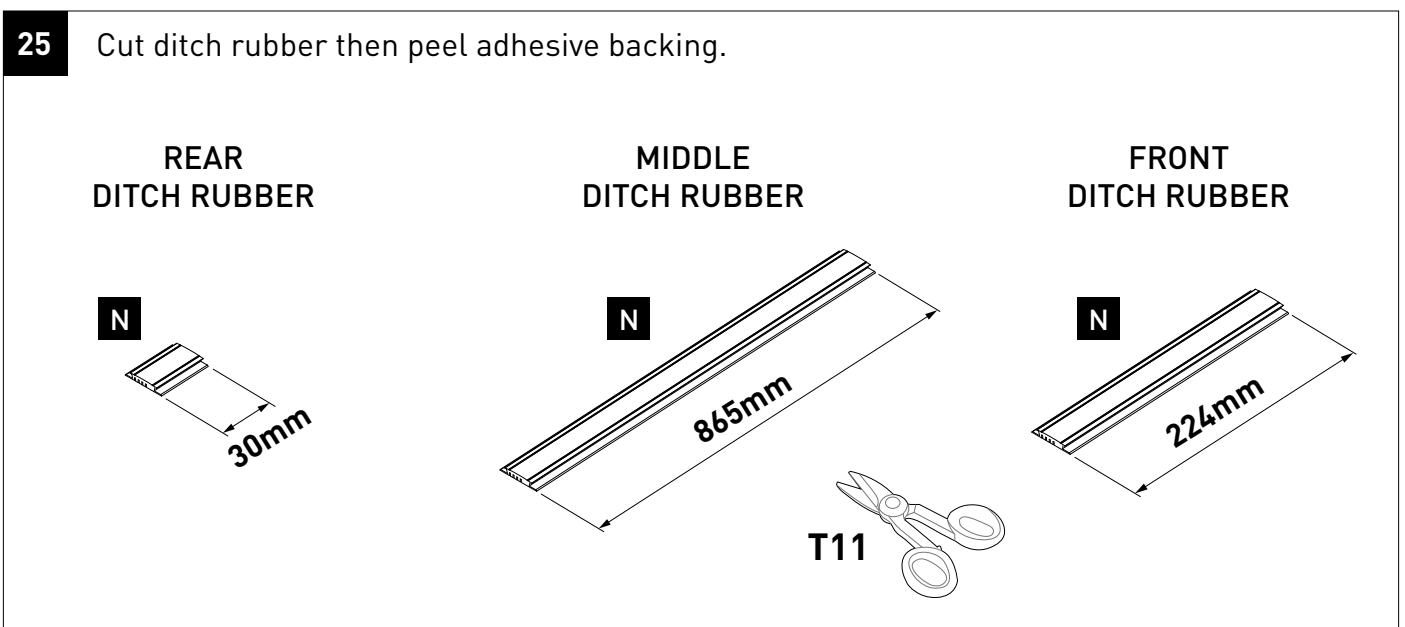
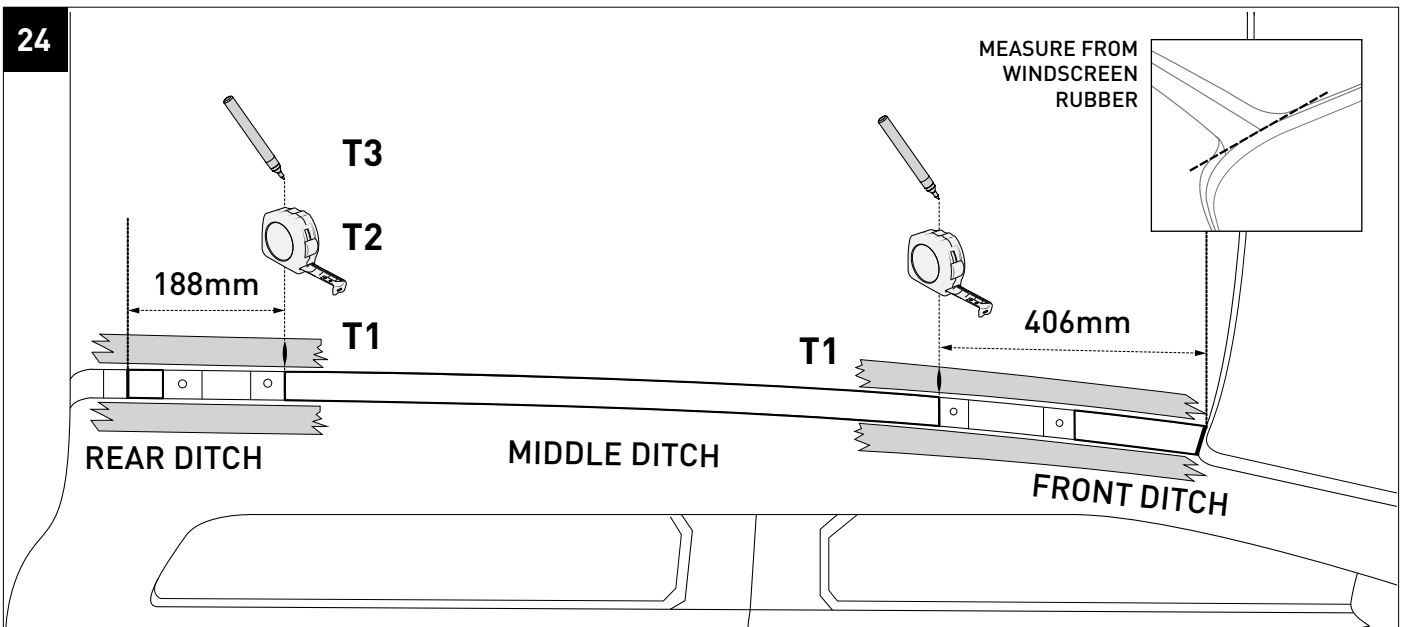
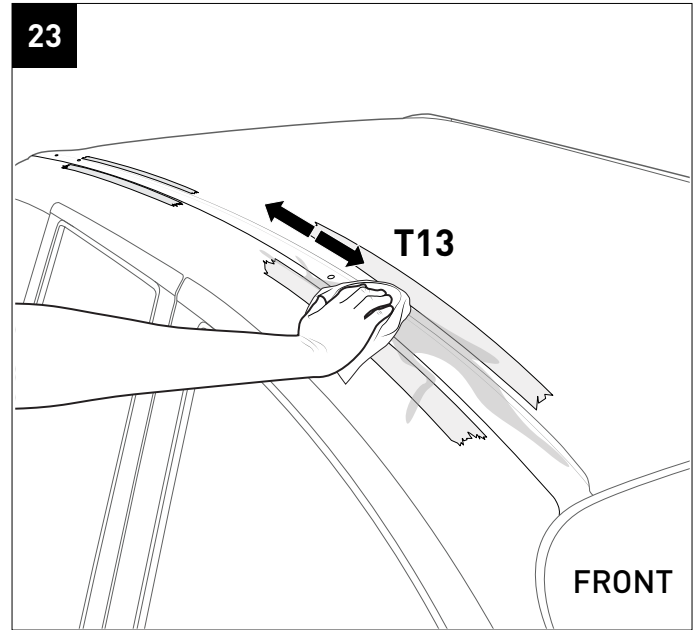
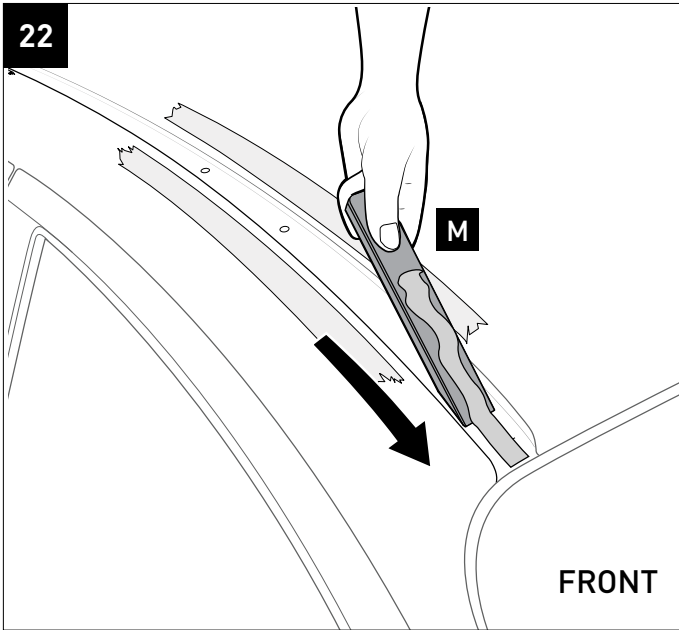

26 Adhere ditch rubber to roof ditch. Repeat **16** - **26** to opposite rail

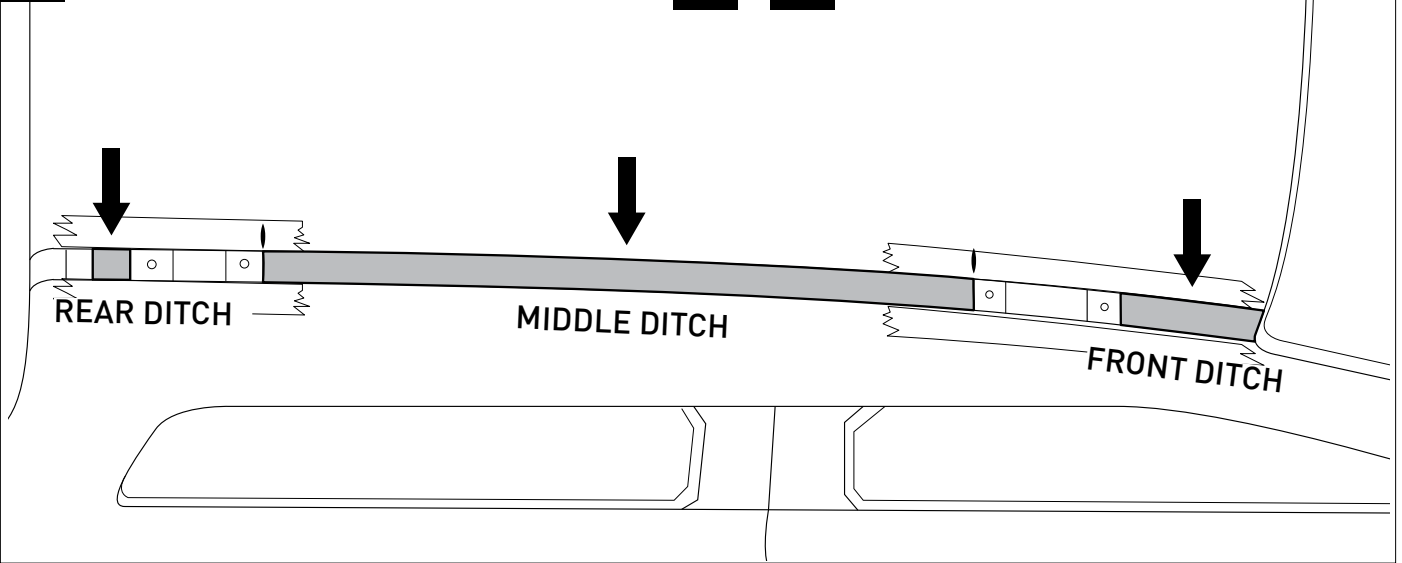

27

27a

27b

27c

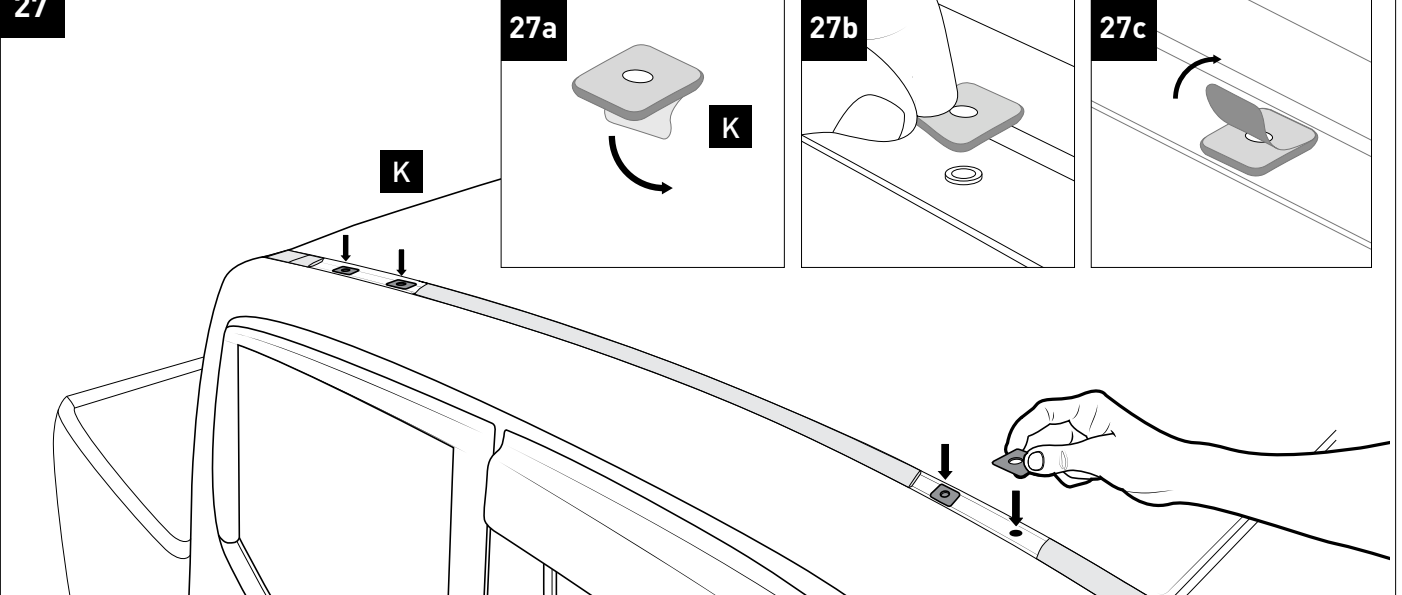

28

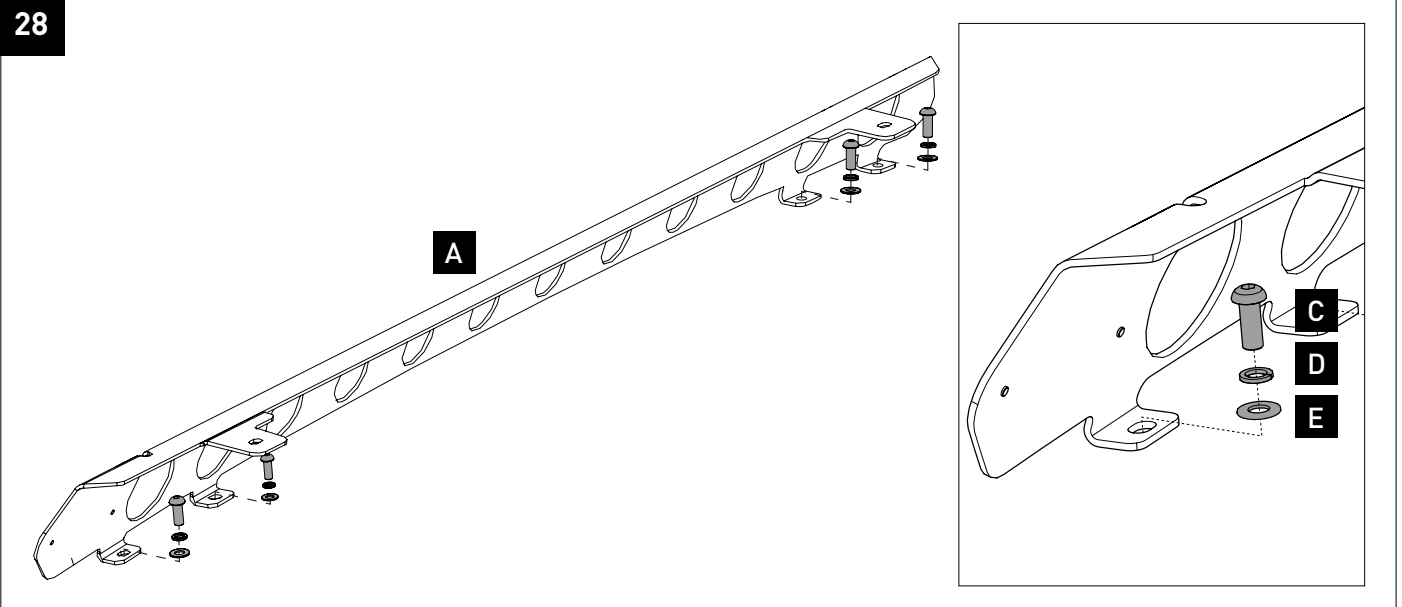

29

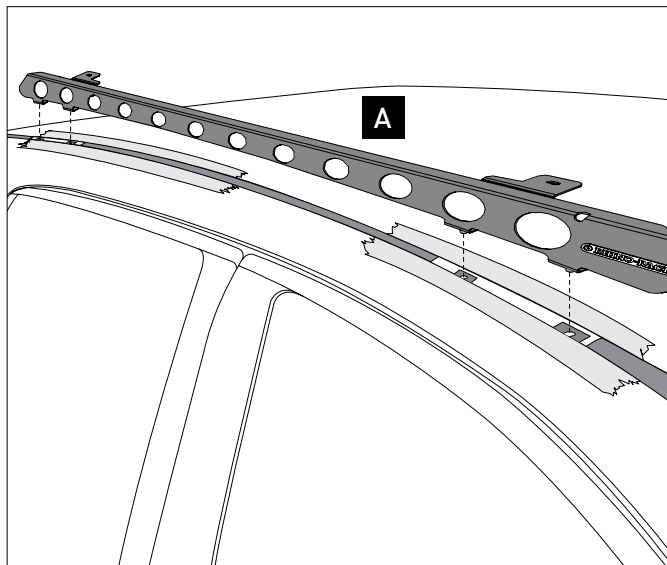
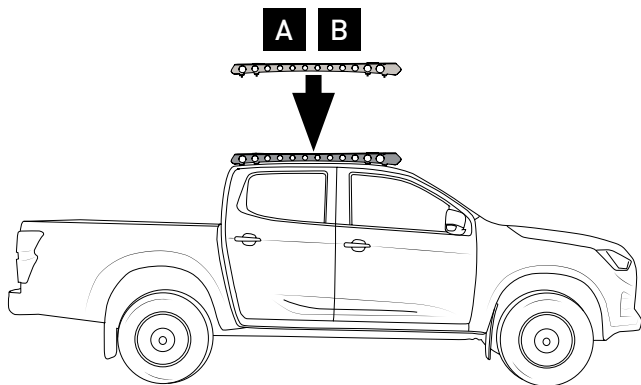

30

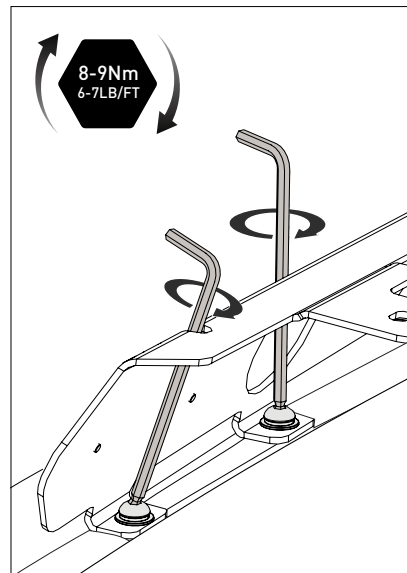
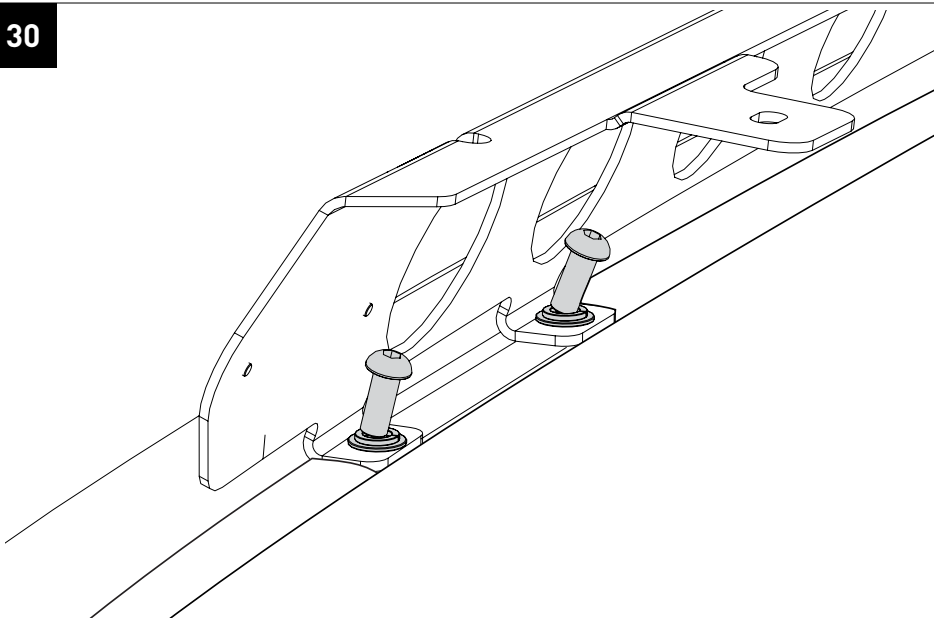

31 Trim ditch molds to fill gaps. Repeat steps 27 - 31 to opposite side

FRONT

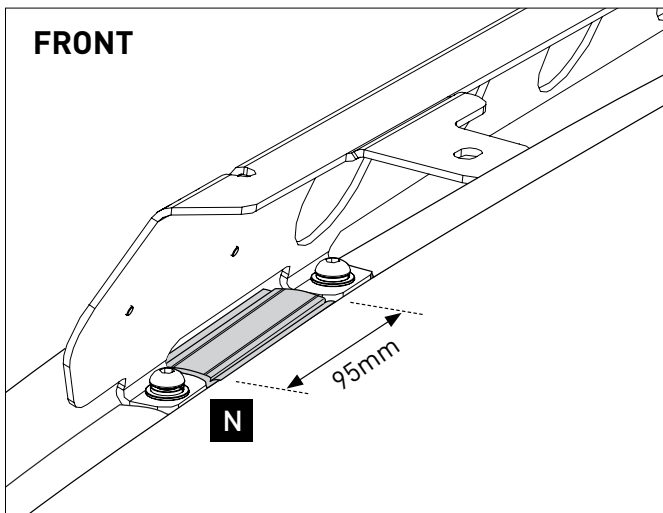

REAR

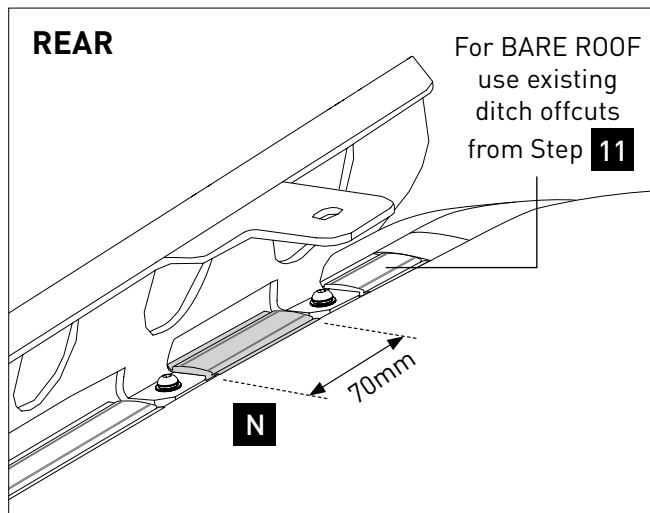

32 Refer to the website for the Pioneer fit chart to suit your vehicle



rhinorack.com/roof

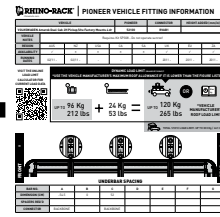
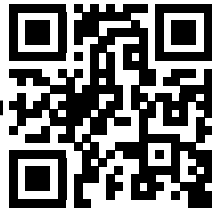

View Fitting Chart

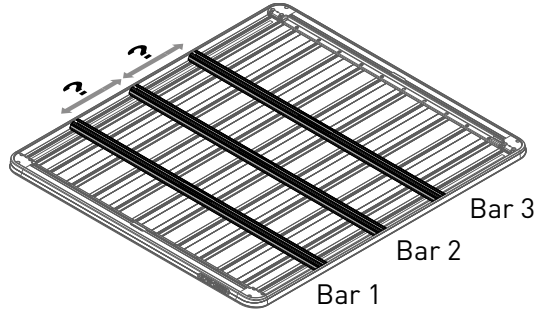

33 For 5XXX series Platform

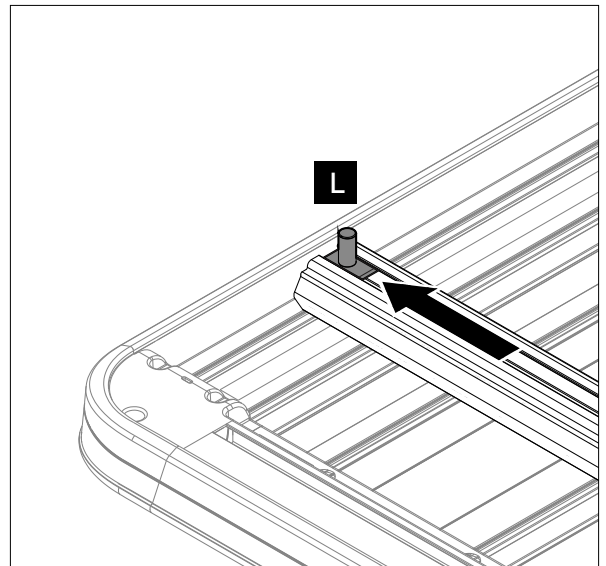
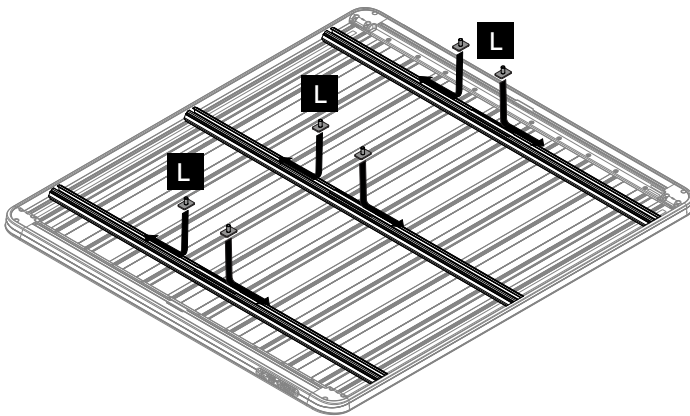

33a For 5XXX series Platform

Repeat for the 4 tabs on top of the backbone rails (2 each rail).

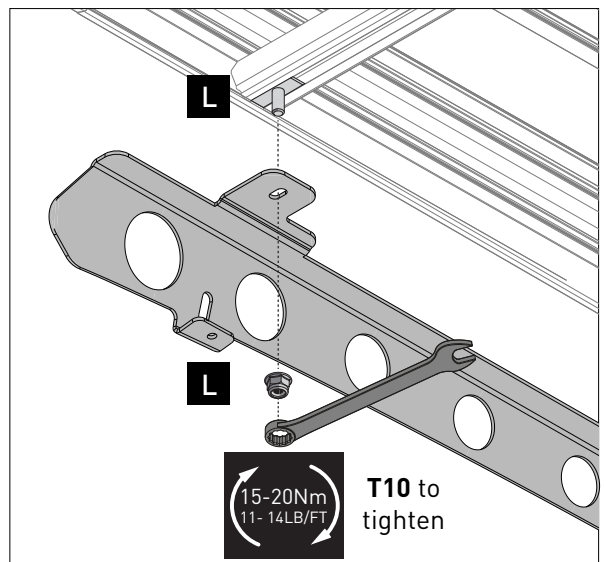
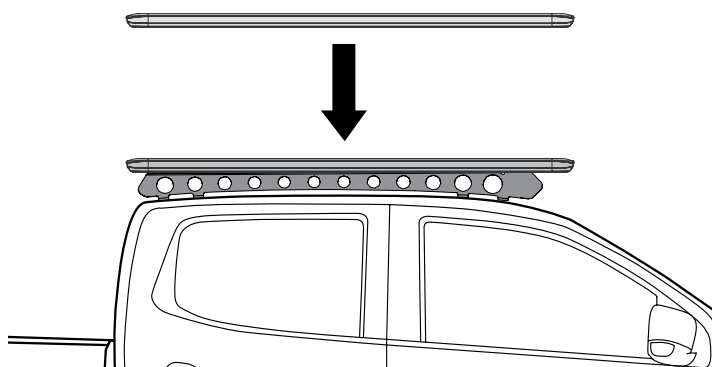

34 For 4XXX series Platform

Repeat for the 4 tabs on top of the backbone rails (2 each rail).

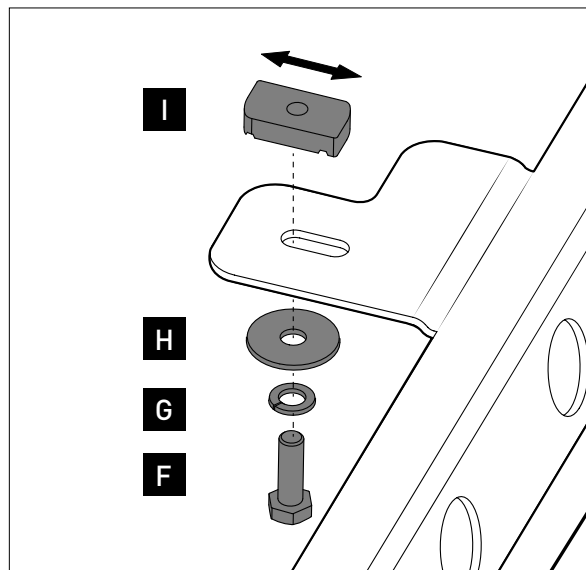
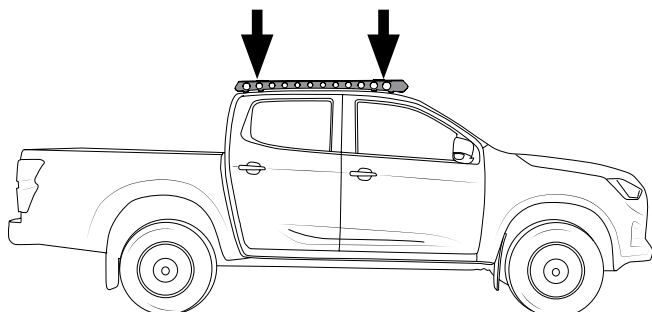

34a For 4XXX series Platform

After underbars have been correctly fitted, place the Pioneer Platform on the Backbone.

Align the underbars with the top tabs and ensure the M8 hardware fits into underbar channel.

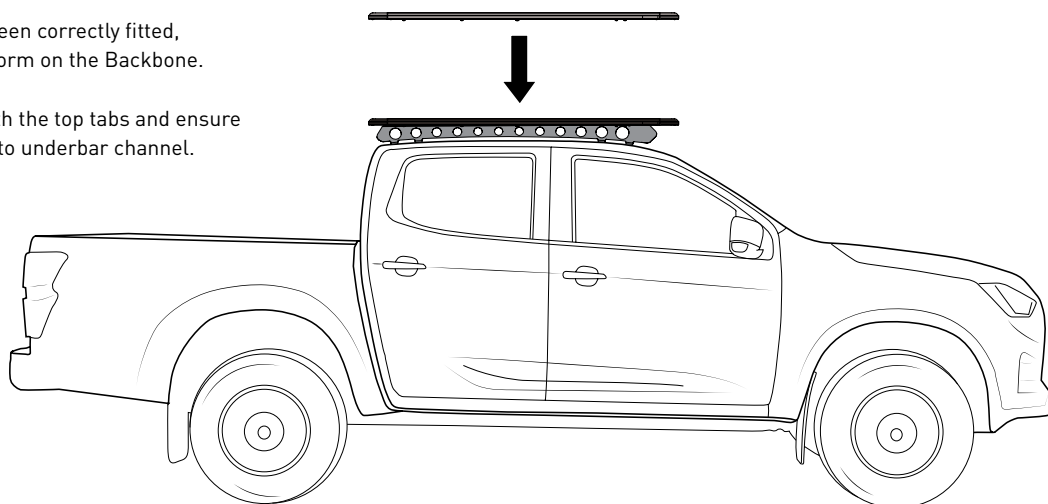

34b

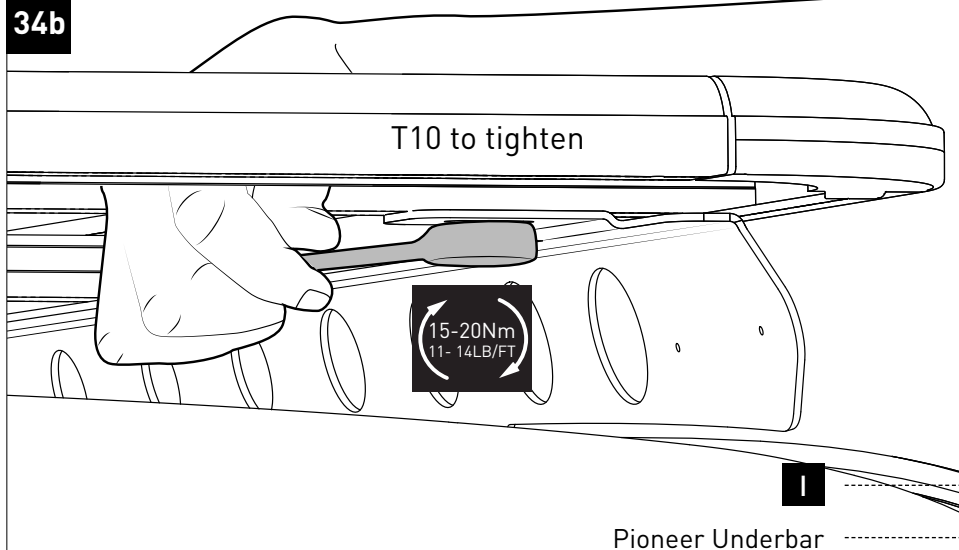

Ensure channel nut has rotated within Pioneer underbar and is fixing Pioneer securely.

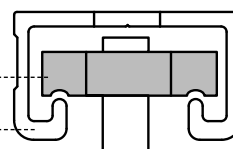

NOTES

NOTES

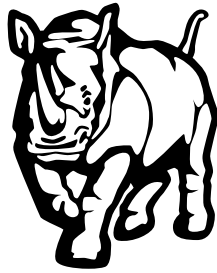

RHINO-RACK®

MAKE SPACE FOR ADVENTURE

RHINORACK.COM

Rhino-Rack AUSTRALIA

22A Hanson Pl,
Eastern Creek, NSW, 2766

Rhino-Rack USA

Unit D, 2450 Airport Blvd,
Aurora, CO, 80011