



CONTROLLED

RHINO-RACK

Recovery Track Strap 43199

For use with Recovery Tracks

Important: Please read these instructions carefully prior to installation.
Please refer to your fitting instruction to ensure that the alloy tray is installed correctly.
Check the contents of this kit before commencing fitment and report any discrepancies.

For use with 43159 75°Degree Bracket

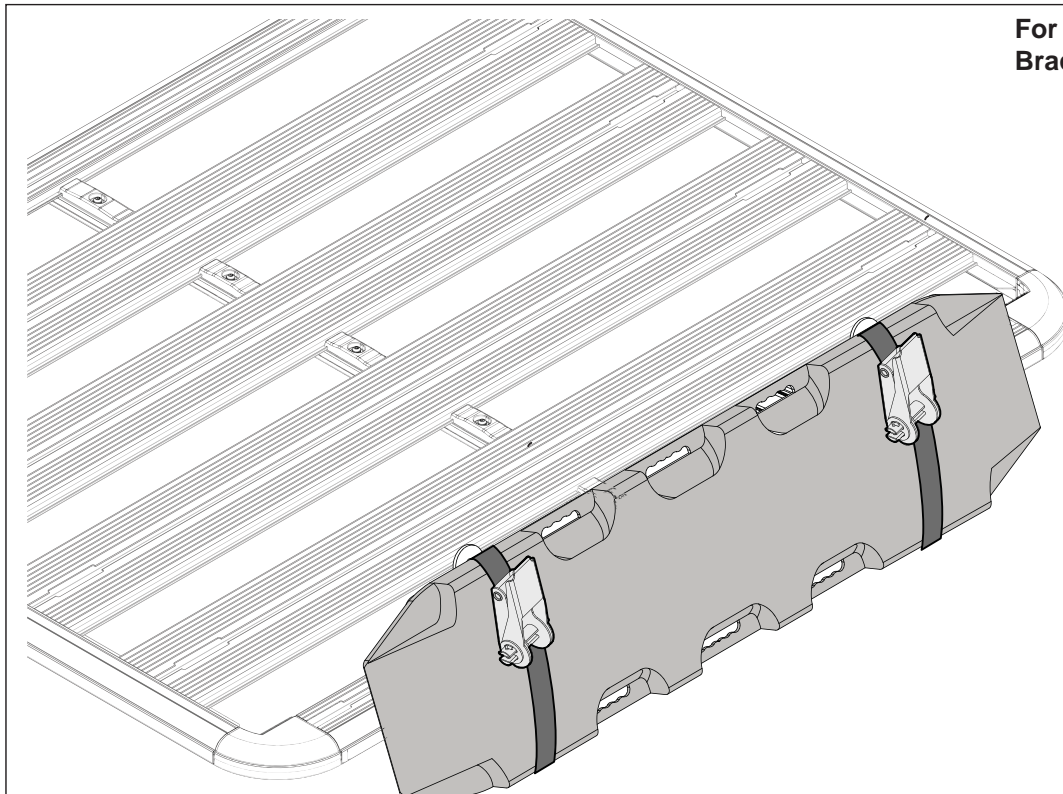

Important Information

Recommendations:

Maximum Lashing Capacity: 225kg/ 496Lbs.

Use only non stretch fastening ropes or straps. Do not overload your Rhino-Rack Pioneer Platform/ Tray or Tradie Tray and roof bars. Check your vehicle's roof carrying capacity. Exercise caution when driving off road as vehicle roof height has been increased. Be aware of increased sensitivity to cross winds.

- Regularly check strap condition for any signs of abrasion. Immediately replace. Do not use a strap that is damaged.
- Do not overload roof capacity. Always evenly distribute load.
- Remove recovery tacks/roof racks/ trays when putting vehicle through an automatic car wash.

Caution:

The handling characteristics of the vehicle change when you transport a load on the roof. For safety reasons, we recommend exercising extreme care when transporting large wind-resisting loads; special consideration must be taken into account when negotiating corners and under braking.

Note for Dealers and Fitters:

It is your responsibility to ensure instructions are given to the end user or client.

Rhino-Rack
3 Pike Street, Rydalmere,
NSW 2116, Australia.
(Ph) (02) 9638 4744
(Fax) (02) 9638 4822

Document No: R736
Prepared By: Kayle Everett
Authorised By: Chris Murty

Fit time: 5min
Issue No: 01
Issue Date: 24/06/15

These instructions remain the property of RhinoRack Australia Pty. Ltd. and may not be used or changed for any other purpose than intended.



Recovery Track Strap 43199

For use with Recovery Tracks

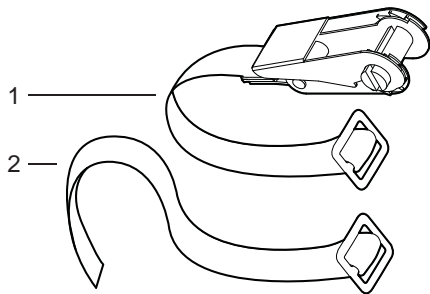

Item	Component	Qty	Part No.
1	Upper Recovery Track Strap	2	CA1450
2	Lower Recovery Track Strap	2	
3	Fitting Instructions	1	R736

1 Slide the metal buckle on the Upper and lower Recovery Track Strap through the inserts on the Side Bracket as shown. Rotate both buckles down into a locked position.

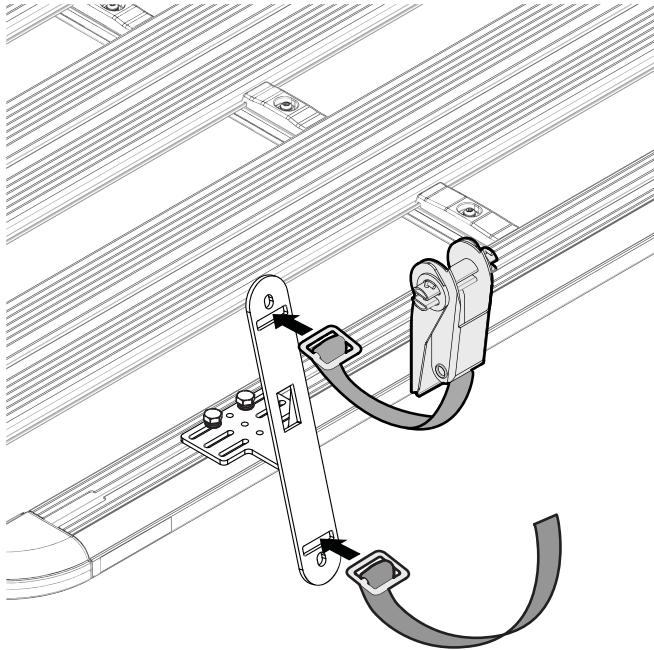

Rear of Bracket

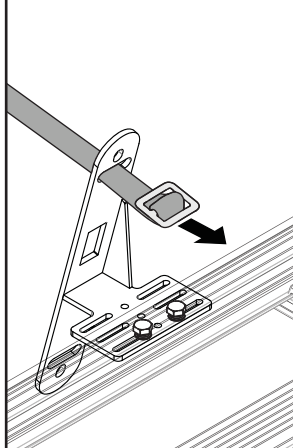

Side View

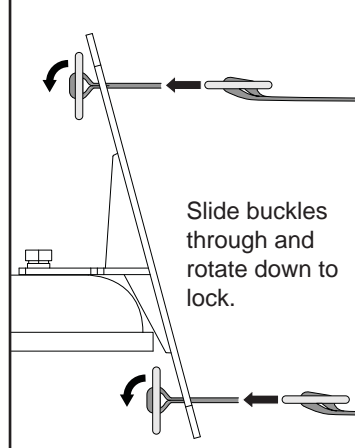

2 With assistance, place the Recovery Track onto the Bracket as shown.

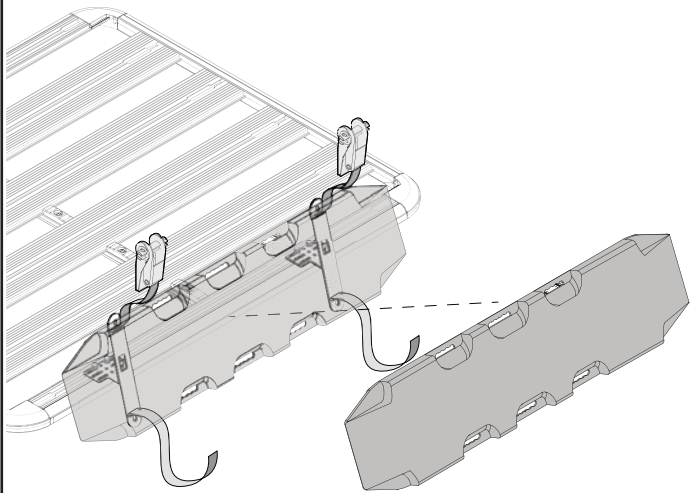

Setup example only.

3 Pull the strap through the Ratchet as shown. Tighten over the load to be carried. Ensure load is secure before driving.

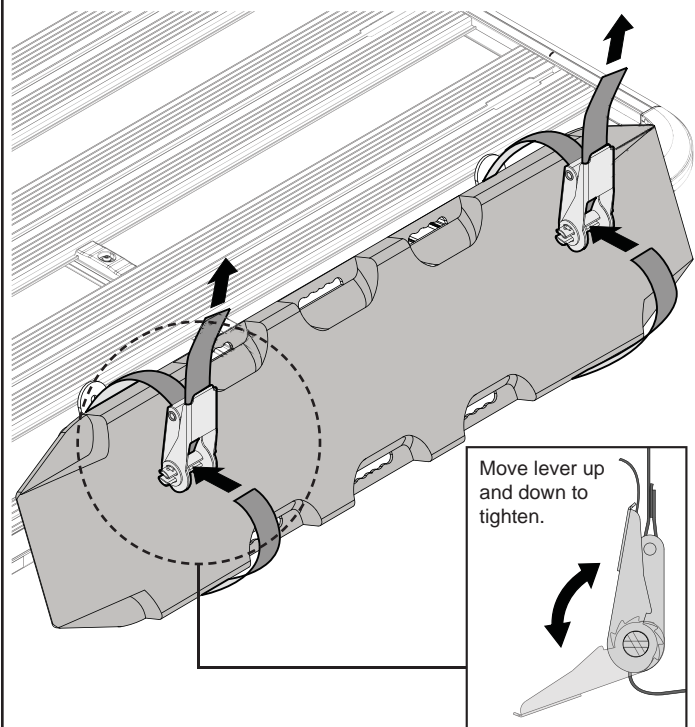

4 Roll up any excess strap and use the velcro tabs just behind the ratchet to secure. This will decrease wind noise.

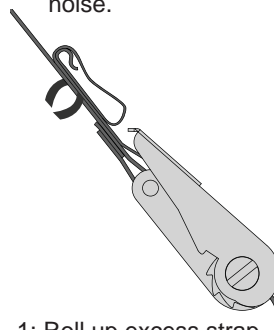

1: Roll up excess strap.

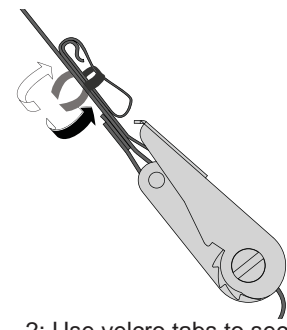

2: Use velcro tabs to secure.